

### 概述

#### 概述:

SCSR118是一款基于超再生原理的集成无线接收芯片。SCSR118内部集成了前置低噪放大器，超再生振荡器，熄灭信号发生器，包络检波解调器等电路。芯片工作在315MHz/433MHz的ISM(Industrial, Scientific and Medical)频段，采用OOK(On Off Keying)调制方式。

芯片将接收到的RF信号解调，输出CMOS电平数据信号，做到了“数据入，数据出”。芯片工作电压为4.5~5.5V，5V时消耗电流4mA，典型灵敏度优于-95dBm。最大数据速率为10Kbit/s，工作温度范围-20℃至+85℃，提供SOP8封装。

### 特性

- ◆ 集成OOK无线接收芯片
- ◆ 输入无需50Ω匹配
- ◆ 工作速率<10Kbit/s
- ◆ 4.5~5.5V电源工作
- ◆ 低功耗，高灵敏度
- ◆ 稳定性好，调试方便
- ◆ 上电时间<20ms
- ◆ 数据入，数据出

### 应用

- ◆ 报警和安全系统
- ◆ 家庭自动化控制
- ◆ 自动测试系统
- ◆ 车辆安全系统
- ◆ 遥控装置
- ◆ 工业控制
- ◆ 短距无线通信

### 封装图

SOP8封装

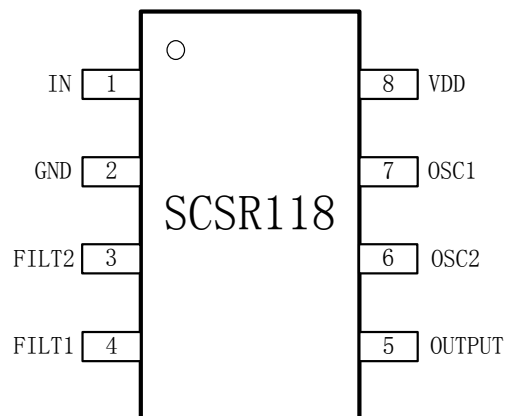



图1. 典型应用电路（一）

SCSR118 工作在 315MHz 时的典型参数:

器件名称	值	备注
$C_{ant}$	100pF	
$C_{in}$	3.6pF	5%精度要求
$L_{in}$	33nH	5%精度要求(Q值尽可能好)
$C_{vdd}$	0.1uF+0.01uF(并联)	电源滤波
$C_1$	0.47uF	
$C_2$	4.7nF	
$C_{osc}$	4.7 pF	5%精度要求
$L_{osc}$	大约 38nH	3.5T 可调电感(铜芯, 推荐使用科达嘉)

SCSR118 工作在 433.92MHz 时的典型参数:

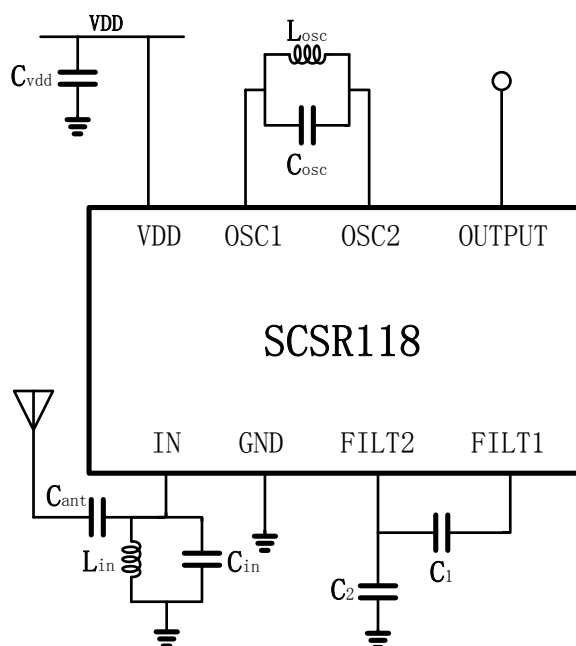
器件名称	值	备注
$C_{ant}$	100pF	
$C_{in}$	4.7pF	5%精度要求
$L_{in}$	18nH	5%精度要求(Q值尽可能好)
$C_{vdd}$	0.1uF+0.01uF(并联)	电源滤波
$C_1$	0.47uF	
$C_2$	4.7nF	
$C_{osc}$	3.6 pF	5%精度要求
$L_{osc}$	大约 25nH	2.5T 可调电感(铜芯, 推荐使用科达嘉)



图2. 典型应用电路 (二)

SCSR118 工作在 315MHz 时的典型参数:

器件名称	值	备注
$C_{ant}$	100pF	
$C_{in}$	3.6pF	5%精度要求
$L_{in}$	33nH	5%精度要求 (Q 值尽可能好)
$C_{vdd}$	0.1uF+0.01uF (并联)	电源滤波
$C_1$	0.47uF	
$C_2$	4.7nF	
$C_{osc}$	4.7 pF	5%精度要求
$L_{osc}$	大约 38nH	3.5T 可调电感 (铜芯, 推荐使用科达嘉)
$R_1$	22M $\Omega$	

SCSR118 工作在 433.92MHz 时的典型参数:

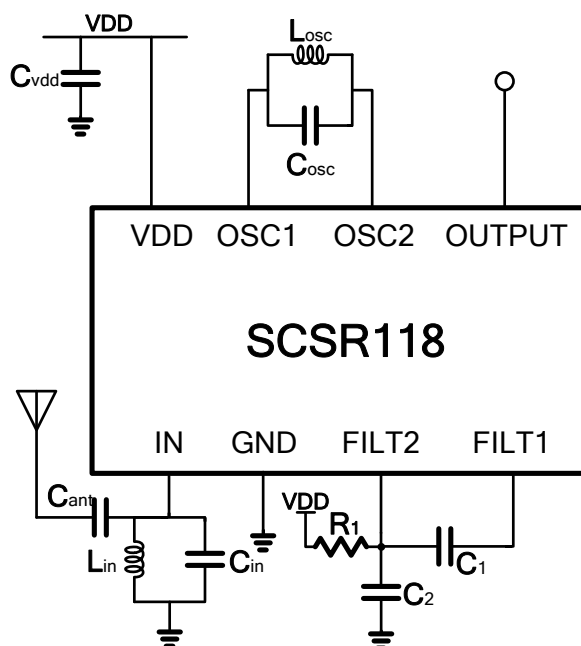
器件名称	值	备注
$C_{ant}$	100pF	
$C_{in}$	4.7pF	5%精度要求
$L_{in}$	18nH	5%精度要求 (Q 值尽可能好)
$C_{vdd}$	0.1uF+0.01uF (并联)	电源滤波
$C_1$	0.47uF	
$C_2$	4.7nF	
$C_{osc}$	3.6pF	5%精度要求
$L_{osc}$	大约 25nH	2.5T 可调电感 (铜芯, 推荐使用科达嘉)
$R_1$	22M $\Omega$	

**Absolute Maximum Ratings**

SYMBOL	PARAMETER	RATING	UNITS
V <sub>CC</sub>	Power supply	-0.3 to 6	V
T <sub>A</sub>	Operating ambient	-40 to +85	°C
T <sub>STG</sub>	Storage temperature	-65 to +150	°C
T <sub>Lead</sub>	Lead Temperature (soldering, 10s)	300	°C
T <sub>jmax</sub>	Maximum junction temperature	150	°C
ESD	ESD in HBM	>2000	V

**Note:** Stresses beyond those listed under "Absolute Maximum Ratings" may cause permanent damage to the device. These are stress ratings only, and functional operation of the device at these or any other conditions beyond those indicated in the operational sections of the specifications is not implied. Exposure to absolute maximum rating conditions for extended periods may affect device reliability.

**Recommended Operating Conditions**

SYMBOL	PARAMETER	RATING	UNITS
V <sub>CC</sub>	Power supply(Note 1)	4.5 to 5.5	V
T <sub>A</sub>	Operating ambient	-40 to +85	°C

**Note 1:** Related to Ground

**ELECTRICAL CHARACTERISTICS**

(V<sub>CC</sub> = +4.5V to +5.5V, inputs and outputs terminated with 50Ω, T<sub>A</sub> = -40°C to +125°C, MOSFET model is FF, TT, SS , unless otherwise noted. Typical values are at V<sub>CC</sub> = +5V and T<sub>A</sub> = +25°C, MOSFET MODEL is TT.)

PARAMETER	SYMBOL	CONDITIONS	MIN	TYP	MAX	UNITS
<b>Power supply and Temperature</b>						
Supply	V <sub>CC</sub>		4.5	5	5.5	V
Junction Temperature	T		-40	25	125	°C
Supply current	I <sub>cc</sub>			4		mA

Input characteristics						
Input sensitivity(dBm)	$V_{in}$	50 Ohm match (Note 1)		-95		dBm
Input impedance						
Input carrier frequency	$f_c$			433 315		MHz
Quench frequency	$f_Q$			600		kHz
Data rate				10		kb/s
Maxim input level				0		dBm
OUTPUT Characteristics						
CMOS/TTL Output-Voltage High	$V_{OH}$		$V_{CC}-0.2$			V
CMOS/TTL Output-Voltage Low	$V_{OL}$				0.4	V
LNA Characteristics						
Input impedance	Z11	@315MHz		17-124j		
1dB Compression Point	P1dB			-8.1		dbm
Gain		@315MHz		20		dB
Isolatuion		SRO Signal Feed through to Antenna		-60		dB

Note 1 : BER=1e-3

引脚名称	对应 SOP8 封装 PIN 脚序号	功能
IN	1	信号输入端
GND	2	地
FILT2	3	外接滤波器电容到地
FILT1	4	外接滤波器电容到FILT2
OUT	5	数据输出
OSC2	6	振荡器输出端，外接LC器件
OSC1	7	振荡器输出端，外接LC器件
VDD	8	4.5~5.5V电源

SCSR118由前置低噪放大器，超再生振荡器，熄灭信号发生器，包络检波解调器组成，如图2所示。超再生振荡器工作在间歇振荡状态，由熄灭信号产生电路控制，在每个振荡周期内，振荡器根据输入信号的强弱改变起振时间，输入信号强，起振时间短，反之亦然。经过包络检波电路后，这种变化的起振时间被转换为宽度不同的包络信号，包络宽的信号被解调为逻辑“1”，包络窄的信号被解调为逻辑“0”，从而得到最终的输出数据信号。



图3. 原理图

## SOP8 Package Outline Dimensions

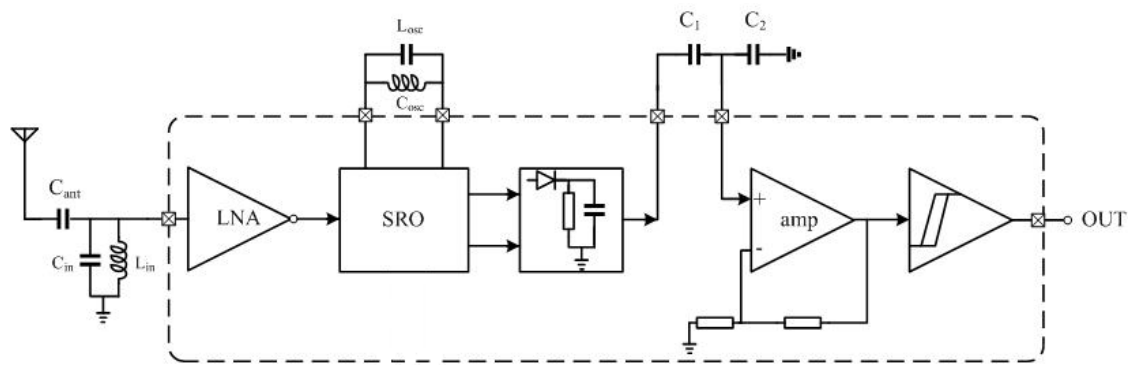
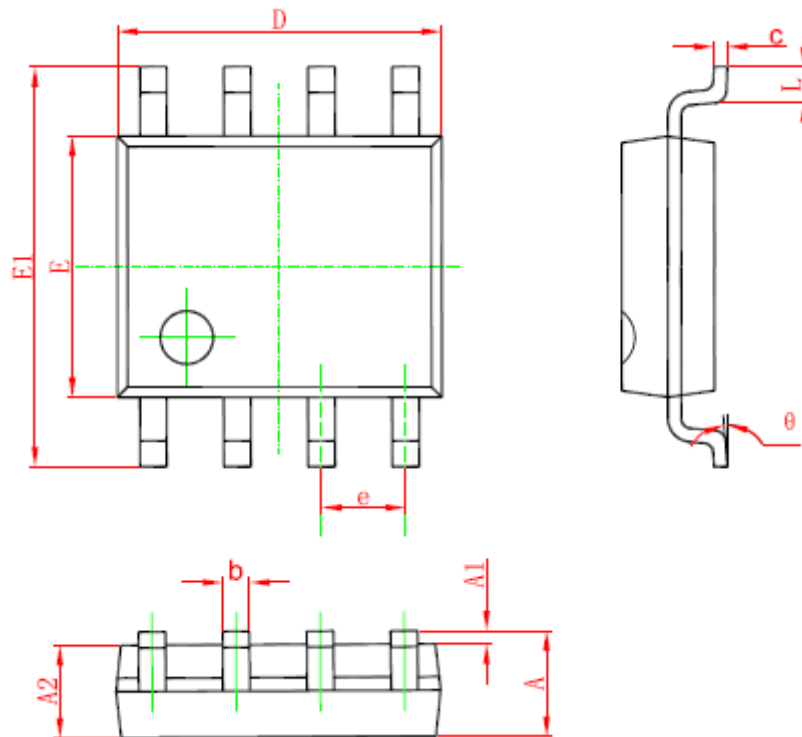

Symbol	Dimensions In Millimeters		Dimensions In Inches	
	Min	Max	Min	Max
A	1.350	1.750	0.053	0.069
A1	0.100	0.250	0.004	0.010
A2	1.350	1.550	0.053	0.061
b	0.330	0.510	0.013	0.020
c	0.170	0.250	0.006	0.010
D	4.700	5.100	0.185	0.200
E	3.800	4.000	0.150	0.157
E1	5.800	6.200	0.228	0.244
e	1.270 (BSC)		0.050 (BSC)	
L	0.400	1.270	0.016	0.050
θ	0°	8°	0°	8°