

### General Description:

SCSR120L is a single chip Super Regenerative Receiver(SRR) RF IC .

SCSR120L is composed of an low noise pre-amplifier, the super regenerative oscillator, off Signal Generator, the envelope detector demodulator , etc. The chip operates at 315MHz/433MHz ISM (Industrial, Scientific and Medical) band, using OOK (On Off Keying) modulation.

The chip demodulate the received RF signal and outputs the CMOS level data signal, so that the "data in, data out." is achieved .Chip operating voltage is 2.3 ~ 3.6V,current consumption is 2.3mA at 3.3V operating voltage , typical sensitivity is better than -95dBm. The maximum data rate is 10Kbit / s, Operating temperature range from -20 ° C to +70° C.

### Features

- ◆integrated OOK RF receiver chip
- ◆No need 50Ω input match
- ◆ Data Rate <10Kbit / s
- ◆2.3 ~ 3.6V power supply
- ◆ Low power consumption, high sensitivity

- ◆ high reliability, easy production
- ◆ Power-on time <20ms
- ◆ data in, data out

### Application

- ◆ Alarm and security systems
- ◆ Home automation control
- ◆ Automatic Test System
- ◆ Vehicle Safety Systems
- ◆ Remote control device
- ◆ Industrial Control
- ◆ Short-range wireless communications

### Package drawing

SOP8 Package

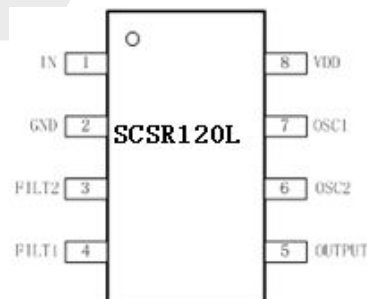

### Typical Application Circuit

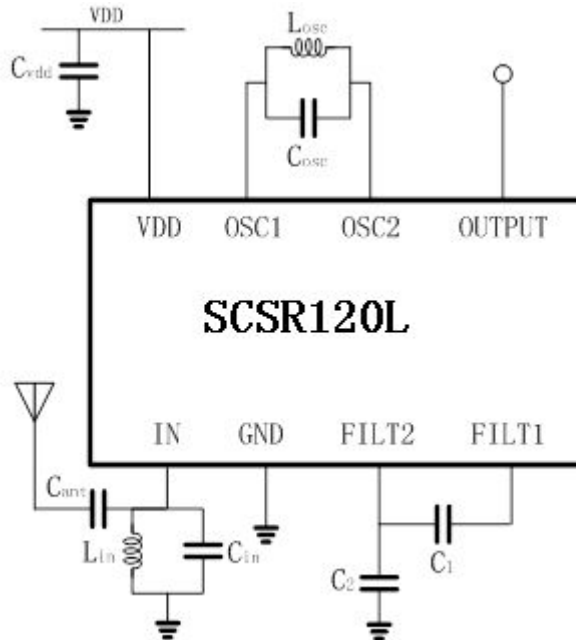

Fig.1. Typical Application Circuit (1)

SCSR120L typical parameters at 315MHz:

Device Name	value	Remark
Cant	100pF	
Cin	3.6pF	5% accuracy requirement
Lin	33nH	5% accuracy requirement (Q value as well as possible)
Cvdd	0.1uF+0.01uF (In parallel)	Power supply filtering
C1	0.47uF	
C2	4.7nF	
Cosc	5 pF	2.5% accuracy
Losc	About 32nH	3.5T adjustable inductance (CODACA)
R1	22MΩ	5% accuracy requirement

SCSR120 L typical parameters at 433.92MHz:

Device Name	value	Remark
Cant	100pF	
Cin	4.7pF	5% accuracy requirement
Lin	18nH	5% accuracy requirement (Q value as well as possible)
Cvdd	0.1uF+0.01uF (In parallel)	Power supply filtering
C1	0.47uF	
C2	4.7nF	
Cosc	4 pF	2.5% accuracy
Losc	About 20nH	2.5T adjustable inductance ( CODACA)
R1	22MΩ	5% accuracy requirement

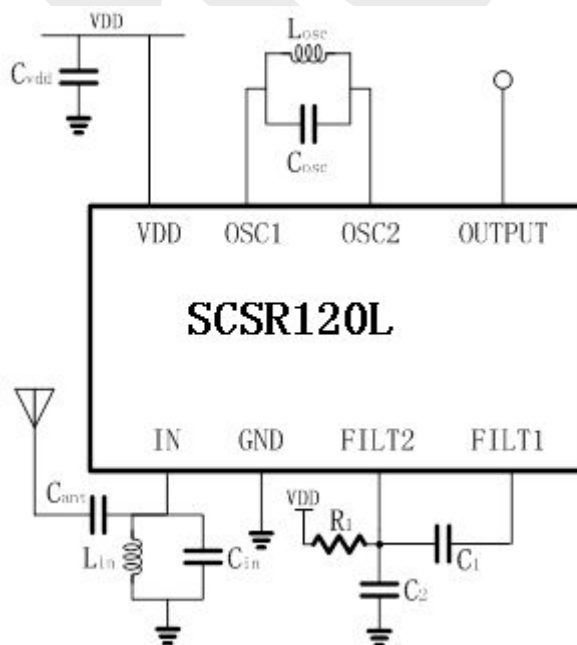

Fig.2. Typical Application Circuit (2)

**Absolute Maximum Ratings**

SYMBOL	PARAMETER	RATING	UNITS
V <sub>CC</sub>	Power supply	-0.3 to 6	V
T <sub>A</sub>	Operating ambient	-20 to +70	°C
T <sub>STG</sub>	Storage temperature	-65 to +150	°C
T <sub>Lead</sub>	Lead Temperature (soldering, 10s)	300	°C
T <sub>jmax</sub>	Maximum junction temperature	150	°C
ESD	ESD in HBM	>2000	V

**Note:** Stresses beyond those listed under “Absolute Maximum Ratings” may cause permanent damage to the device. These are stress ratings only, and functional operation of the device at these or any other conditions beyond those indicated in the operational sections of the specifications is not implied. Exposure to absolute maximum rating conditions for extended periods may affect device reliability.

**Recommended Operating Conditions**

SYMBOL	PARAMETER	RATING	UNITS
V <sub>CC</sub>	Power supply(Note 1)	2.3 to 3.6	V
T <sub>A</sub>	Operating ambient	-20 to +70	°C

**Note 1:** Related to Ground



# SCSR120L

## 250-450MHz ASK SRR Receiver

### ELECTRICAL CHARACTERISTICS

(VCC = +2.3V to +3.6V, inputs and outputs terminated with 50Ω, TA = -40°C to +125°C, MOSFET model is FF, TT, SS , unless otherwise noted. Typical values are at VCC = +3.3V and TA = +25°C, MOSFET MODEL is TT.)

PARAMETER	SYMBOL	CONDITIONS	MIN	TYP	MAX	UNITS
<b>Power supply and Temperature</b>						
Supply	VCC		2.3	3.0	3.6	V
Junction Temperature	T		-40	25	125	°C
Supply current	Icc			2.3		mA
<b>Input characteristics</b>						
Input sensitivity(dBm)	Vin	50 Ohm match (BER=1e-2)		-95		dBm
Input impedance						
Input carrier frequency	$f_c$		250	315/ 433	450	MHz
Quench frequency	$f_Q$			600		kHz
Data rate				10		kb/s
Maxim input level				0		dBm
<b>OUTPUT Characteristics</b>						
CMOS/TTL Output-Voltage High	V <sub>OH</sub>		V <sub>CC</sub> -0.2			V
CMOS/TTL Output-Voltage Low	V <sub>OL</sub>				0.4	V
<b>LNA Characteristics</b>						
Input impedance	Z <sub>11</sub>	@315MHz		17-124j		
1dB Compression Point	P <sub>1dB</sub>			-8.1		dbm
Gain		@315MHz		20		dB
Isolatuion		SRO Signal Feed through to Antenna		-60		dB

### PIN INSTRUCTION

PIN NAME	PIN number corresponding to SOP8 package	Pin function
IN	1	Signal input terminal
GND	2	Ground
FILT2	3	External filter capacitor to ground
FILT1	4	External filter capacitor to FILT2
OUT	5	Data Output
OSC2	6	Oscillator output, external LC devices
OSC1	7	Oscillator output, external LC devices
VDD	8	2.3 ~ 3.6V Power Supply

### Circuit principle

SCSR120L is composed of the low noise pre-amplifier, the super-regenerative oscillator, off Signal Generator, the envelope detector demodulator, as shown in Figure 2. Super-regenerative oscillator operates at quenching state, controlled by the quench signal generating circuit ,in each oscillation cycle, the oscillator changes the start-up time according to the strength of the input signal, if the input signal is strong, the start-up time is short, and vice versa. After envelope detection circuit, the change of the start-up time is converted into an envelope signal of different widths, the wide envelope signal is demodulated into a logic "1", the narrow envelope signal is demodulated into logic "0 ", to obtain the final output data signal.

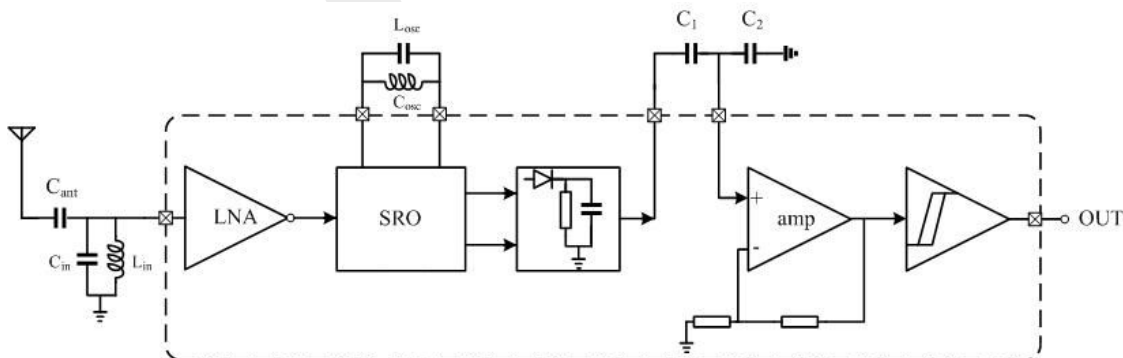
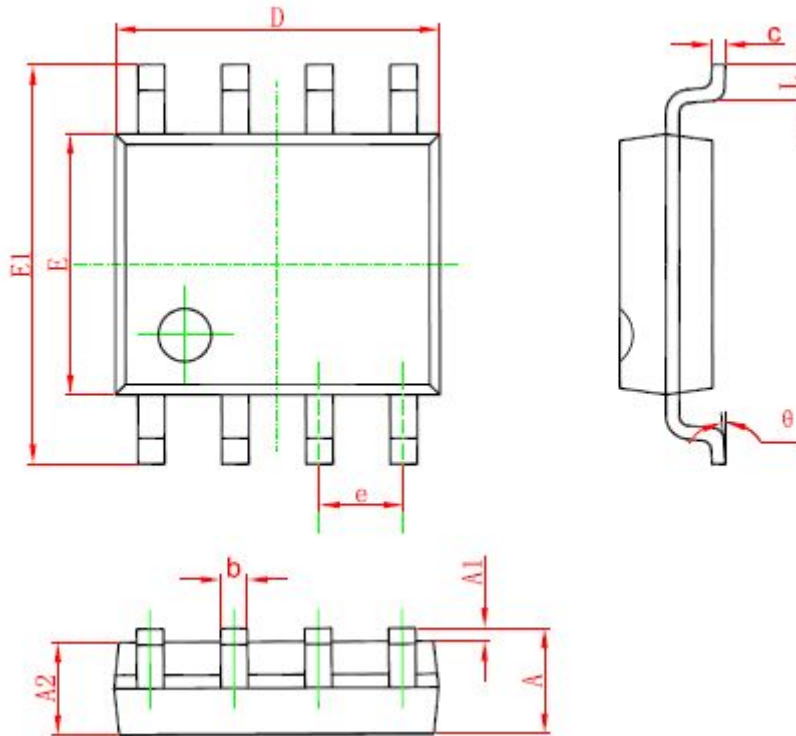

Fig.3. Schematics

### SOP8 Package Outline Dimensions



Symbol	Dimensions In Millimeters		Dimensions In Inches	
	Min	Max	Min	Max
A	1.350	1.750	0.053	0.069
A1	0.100	0.250	0.004	0.010
A2	1.350	1.550	0.053	0.061
b	0.330	0.510	0.013	0.020
c	0.170	0.250	0.006	0.010
D	4.700	5.100	0.185	0.200
E	3.800	4.000	0.150	0.157
E1	5.800	6.200	0.228	0.244
e	1.270 (BSC)		0.050 (BSC)	
L	0.400	1.270	0.016	0.050
θ	0°	8°	0°	8°