

Model Number	Voltage	Max. Load ²	Min. Load ⁵	Ripple ³
LFMWLT40-1000	V1=5.1 V	8.0 A	0.0 A	1%
LFMWLT40-1001	V1=12 V	3.5 A	0.0 A	1%
LFMWLT40-1002	V1=15 V	2.7 A	0.0 A	1%
LFMWLT40-1003	V1=24 V	1.7 A	0.0 A	1%
LFMWLT40-1004	V1=48 V	0.83 A	0.0 A	1%
LFMWLT40-3000	V1=5.2 V, V2=12.5 V, V3=-12.8 V	V1=6.0 A, V2=2.0 A, V3=0.5 A	V1=0.5 A, V2=0.1 A, V3=0.0 A	1%
LFMWLT40-3001	V1=5.2 V, V2=24 V, V3=-12.8 V	V1=6.0 A, V2=1.0 A, V3=0.5 A	V1=0.5 A, V2=0.1 A, V3=0.0 A	1%
LFMWLT40-3002	V1=5.2 V, V2=14.6 V, V3=-14.8 V	V1=6.0 A, V2=1.5 A, V3=0.5 A	V1=0.5 A, V2=0.1 A, V3=0.0 A	1%
LFMWLT40-3003	V1=3.3 V, V2=5.2 V, V3=-12.8 V	V1=6.0 A, V2=3.0 A, V3=0.5 A	V1=1.0 A, V2=0.1 A, V3=0.0 A	V1=1.5%, V2 & V3=1%
LFWLT60-CK metal cover kit accessory				

Connectors		
J1	Pin 1	AC NEUTRAL
	Pin 2	AC LINE
Spade Connector		EARTH
J2	Pin 1	V1
	Pin 2	V1
	Pin 3	RTN
	Pin 4	RTN
	Pin 5	V3
	Pin 6	V2
J3	Pin 1	+V1 SENSE
	Pin 2	-V1 SENSE

Notes

1. For MWLT40-3003 efficiency is 75% typical.
2. Maximum current per output channel. Do not exceed total output power rating.
3. Ripple is peak to peak with 20 MHz bandwidth and 10 μ F (Tantalum capacitor) in parallel with a 0.1 μ F capacitor at rated line voltage and load ranges.
4. Safety approved 47-63 Hz.
5. Min Load specified to meet cross regulation.
6. Add -2 suffix to order Class 2 product.
7. Specifications are for nominal input voltage, 25°C and max. load unless otherwise stated.
8. Derate output power linearly to 80% from 90 VAC to 80 VAC input.



Mechanical Specifications

AC Input Connector (J1)	Molex: 26-60-4030 or equivalent Mating: 09-50-3031; Pins: 08-50-0106
EARTH	Molex: 19705-4301 Mating: 190030001
DC Output Connector (J2)	Tyco: 640445-6 or equivalent Mating: 647402-6; Pins: 3-647409-1
Signal Connector (J3)	Molex: 22-23-2021 or equivalent Mating: 22-01-2021
Dimensions	4.0 x 2.0 x 1.2 inches (101.6 x 50.8 x 30.48 mm)
Weight	150 g
EMC*	
CE Mark	Complies with LVD Directive
Conducted Emissions	EN55022-B, CISPR22-B, FCC PART15-B
Static Discharge	EN61000-4-2, Level-3
RF Field Susceptibility	EN61000-4-3, Level-3
Fast Transients/Bursts	EN61000-4-4, Level-3
Radiated Emissions	EN55022-B, CISPR22-B, FCC PART15-B To be controlled in end system
Surge Susceptibility	EN61000-4-5, Level-3
Harmonic Current	EN61000-3-2, Class A
Safety*	
Safety Standard(s)	EN60601-1, IEC60601-1 (ed.3), ANSI / AAMI ES 60601 - 1, CSA C22.2 No. 60601-1
Approval Agency	Nemko, UL, C-UL
*Safety File Number(s)	Pending

Derating Curve

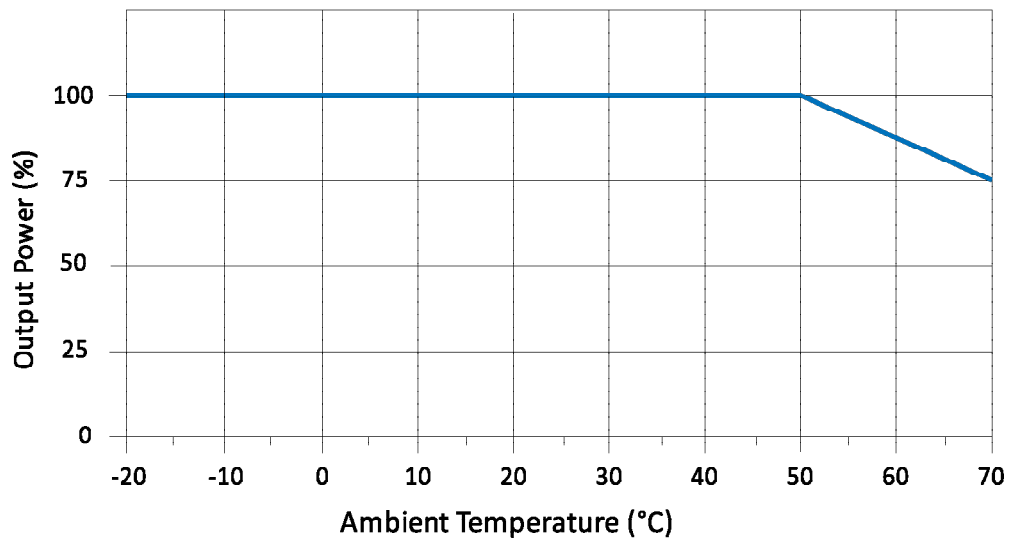

Mechanical Drawing

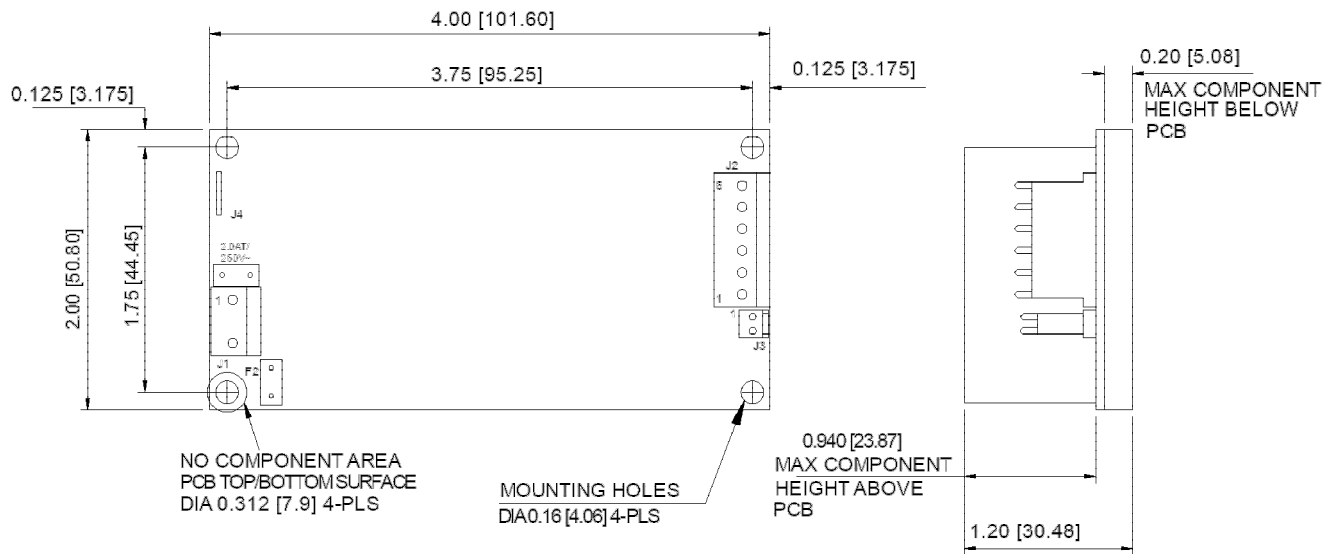

MECHANICAL OUTLINE DIMENSIONS
 ALL DIMENSIONS ARE IN INCHES[MM]
 GEN.TOLERANCE: +/-0.02 [+/-0.5mm]